

## DRA Portable Spot Industrial Salamander Blower Heater



- 7.5 to 30 kW
- 25,590 to 102,360 BTUH
- 208, 240, 480 and 600 Volts
- No Assembly Required
- Built-in Controls

### Description

The Chromalox DRA Dragon is a rugged industrial grade, self contained, highly mobile, electric blower heater. The DRA can be left unattended without the threat of poisoning from combustion by-products associated with fuel fired heaters. The built in safety features include an adjustable thermostat to control the outlet air temperature, auto-reset cutouts for the fan motor and heating elements. The thermostat provides settings for full off, fan only and temperature control in the heating setting. Dragon heaters feature a large, easily accessible control and wiring compartment containing a magnetic contactor; additional safety is provided by a 120 volt control voltage transformer and motor starter on 480 and 600 volt units. The bright red polyester powder coated heating cylinder is highly visible and can be rotated to direct heat or fan driven air movement where it is needed. For assured safety, all standard units meet the requirements of UL (File No. E7061) and CSA (File No. LR40859).

### Construction

#### Heating Cylinder

A structural frame consisting of 2 spun steel rings and 2 formed steel channels support a 20 gauge steel cylinder phosphate coated for corrosion resistance, and finished in red polyester powder coat paint. The heating cylinder pivots vertically to direct air flow.

### Dimensions (Inches)

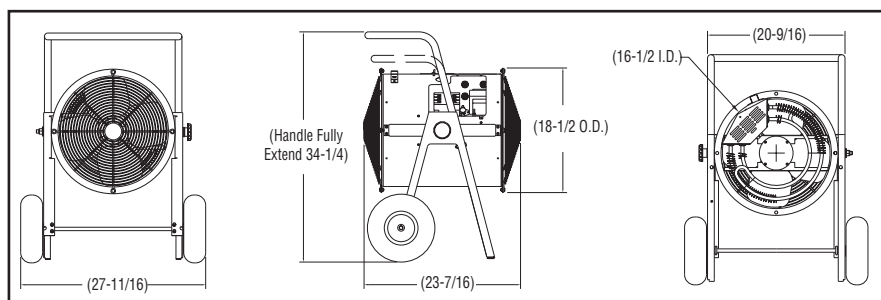

#### Leg Assembly

Each side consists of a one piece, 12 gauge, formed steel member, which accepts a steel tubular handle, held in place with a 1-1/2" long x 1/4" bolt on each side. The handle can be raised from the shipping position if desired. The rubber, pneumatic wheels are 10" diameter and 3 1/2" wide to provide ease of transporting the heater on irregular and gravel surfaces. The large wheels make it easy to roll up stairways without damage to decorative step surfaces.

#### Fan Assembly

The self-centering fan assembly consists of a totally enclosed, permanently lubricated motor and a dynamically balanced aluminum fan blade for smooth, quiet operation.

#### Controls

A thermostat, with a temperature range of 40°F to 100°F is included, with a full off position, a fan only position and an adjustable range of temperature settings in the heating mode position. Each unit includes a 3 pole magnetic contactor and auto-reset thermal cutout. 480 volt and 600 volt units also include a motor relay and 120 volt control voltage transformer for personnel safety.

#### Safety Guards

Front and rear grills are 10 gauge, finished in black polyester powder coat and are designed to meet OSHA safety requirements.

#### Heating Assembly

The patented metal sheath Fintube® heating elements consist of steel fins furnace brazed on industrial grade .475 diameter steel sheath tubular heaters for maximum heat transfer. The elements are held in place with steel bulkhead fittings for durability. The elements feature a high temperature finish for corrosive protection.

### Applications

- For Best Results Use in Enclosed Area with Ceiling Heights Below 15'
- Warming Workers
- Thawing Frozen Pipes
- Thawing Railroad Cars
- Heating Large Tents
- Non-Hazardous Areas